

# OLEÃO OFICIAL USED OIL TANK

**PT****Características**

- ☑ Insensibilidade à corrosão
- ☑ Estanquidade total
- ☑ Elevada resistência aos impactos e às intempéries

**Material**

- ☑ Polietileno

**Acessórios**

- ☑ Manómetro - Indicador de nível

**EN****Characteristics**

- ☑ Insensitivity to corrosion
- ☑ Total tightness
- ☑ High impact and weather resistance

**Material**

- ☑ Polyethylene

**Accessories**

- ☑ Manometer - Level indicator

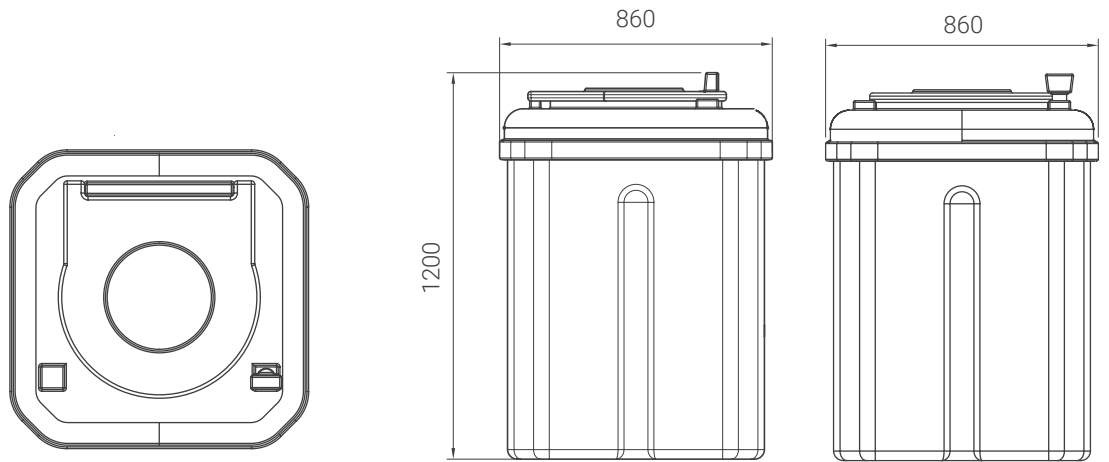

REF.	COMPRIMENTO LENGTH	LARGURA WIDTH	ALTURA HEIGHT	CAPACIDADE VOLUME	COR COLOR
AMBI5702	860 mm	860 mm	1 200 mm	500 l	● RAL 9001

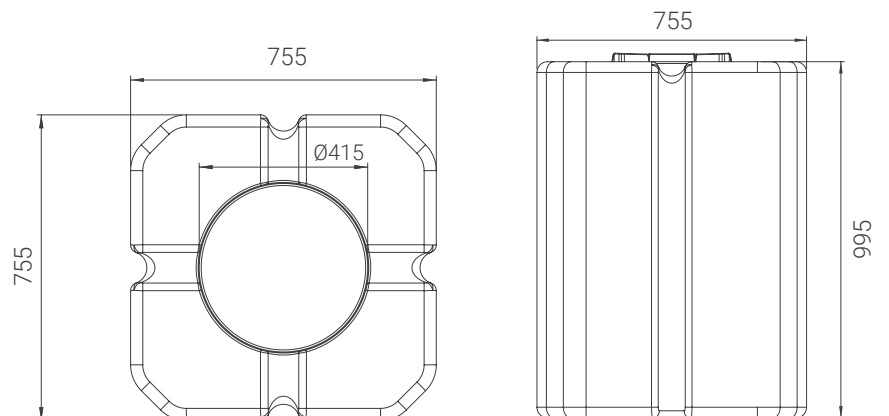

COMPRIMENTO LENGTH	LARGURA WIDTH	Ø ABERTURA Ø OPENING	ALTURA HEIGHT	CAPACIDADE VOLUME	COR COLOR
755 mm	755 mm	415 mm	995 mm	500 l	● RAL 9001